

# Damage and restoration status regarding the Tohoku-Pacific Ocean Earthquake and future prospects

March 30, 2011

Nippon Telegraph and Telephone Corporation

# Damage condition of communication facilities

- Many exchange office buildings and facilities were affected by the large-scale earthquake and tsunami.
- Further damage was caused due to depletion of battery capacity associated with the prolonged disruption in commercial power supply.

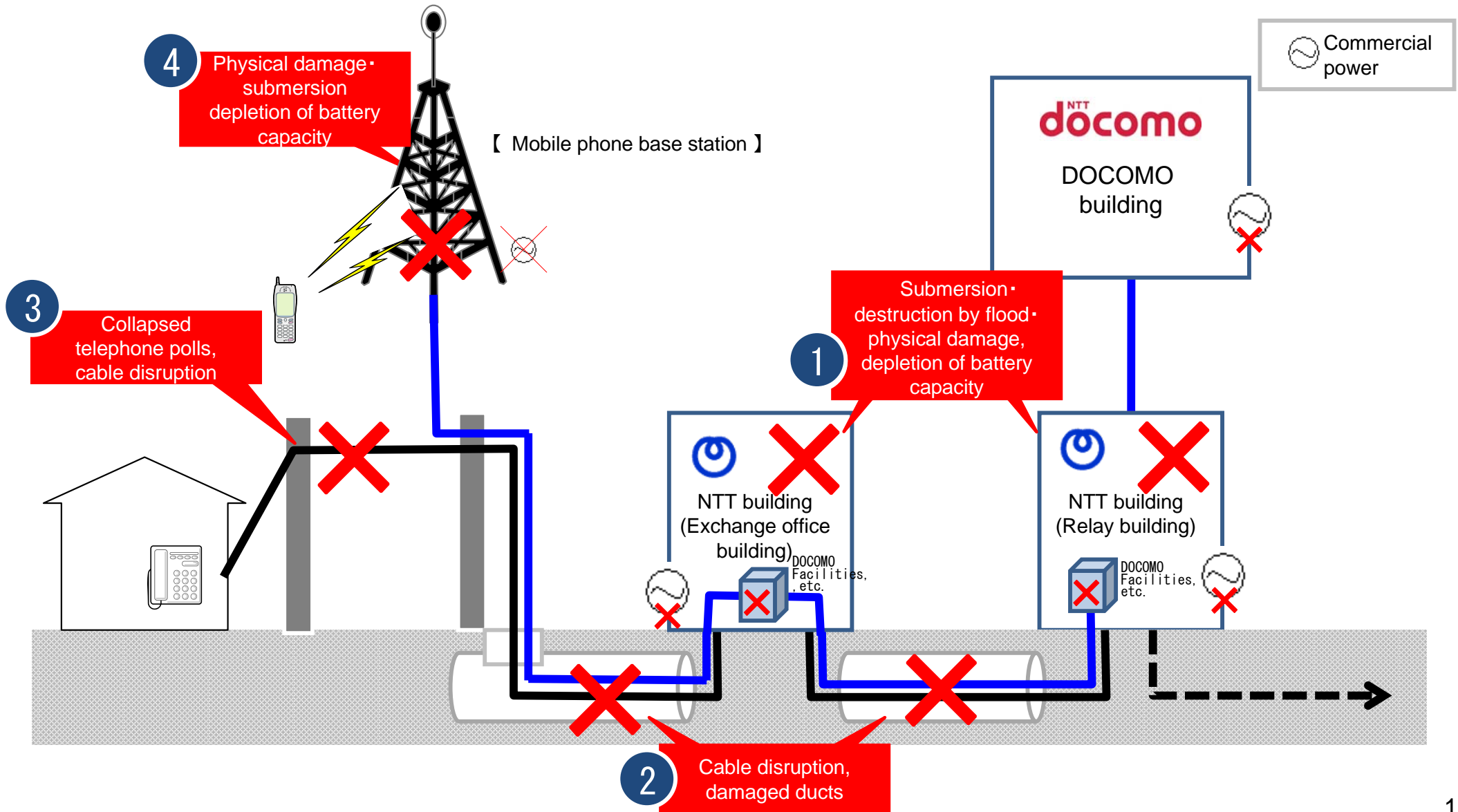

# Restoration status of communication services

- With support from all across the nation, over 10,000 people in total have been making an all-out effort to restore NTT Group's services
- Approximately 90% of exchange offices and mobile base station equipment have been restored through relief efforts by mobile power-supply vehicles and privately-owned power generators, and through facility restoration, such as by using backup relay routes.

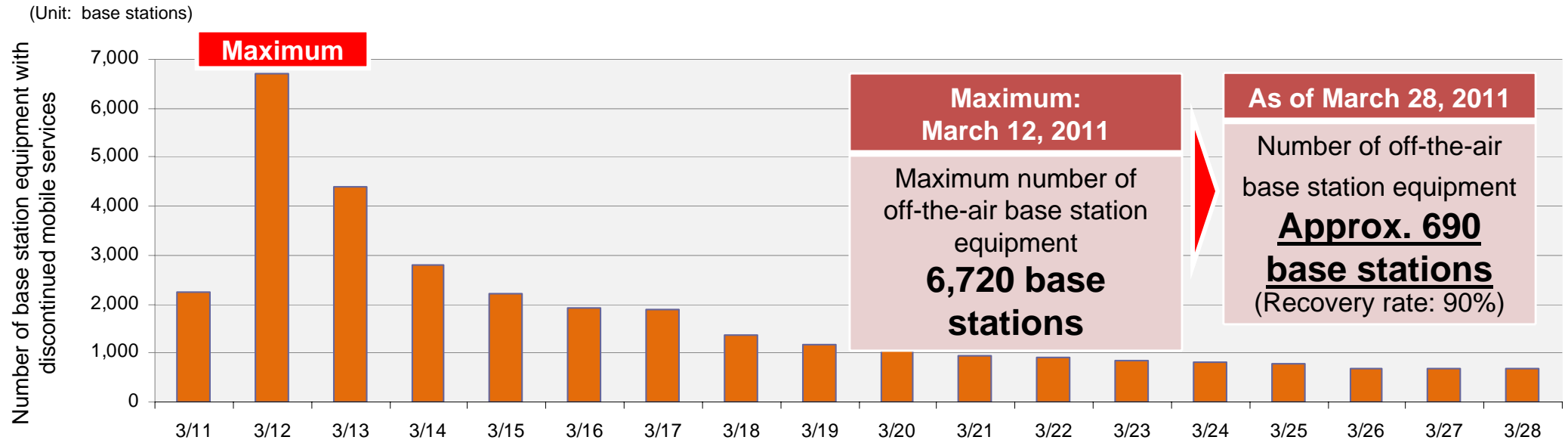
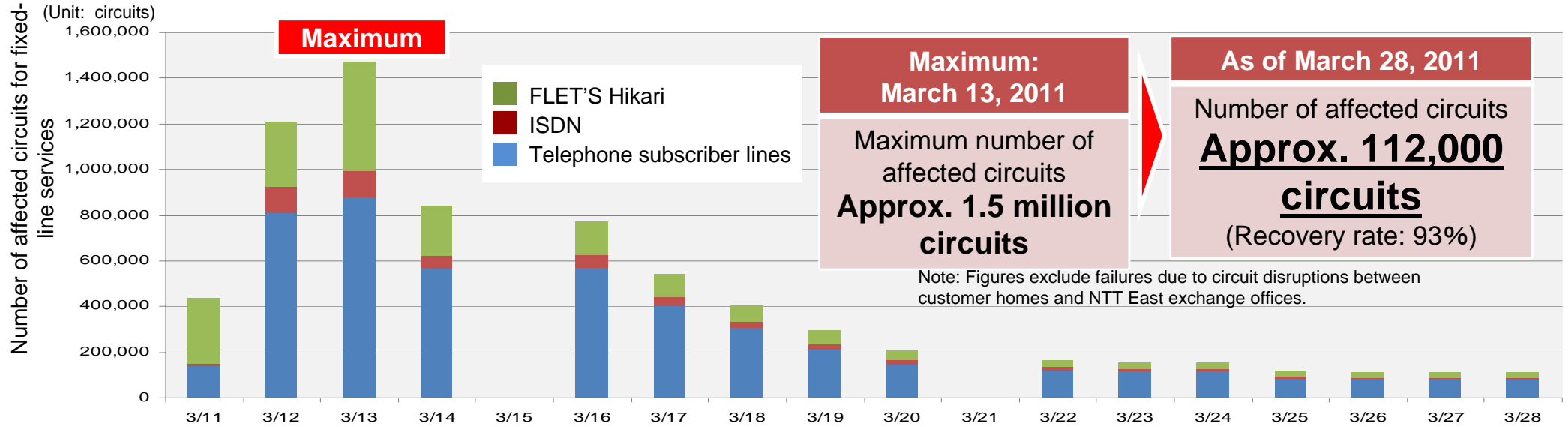

# Future restoration prospects

- Going forward, NTT Group is planning to almost completely restore its services (except certain areas) by the end of April through renewal of power supplies and equipment in exchange offices, re-installation of relay transmission lines, further repair of base stations' relay transmission lines, and area remedies using large zone schemes.
- With regards to the remaining areas, NTT Group will primarily endeavor to restore services in local governments and evacuation centers where in focus, and also improve the communication environment by providing further more satellite mobile phones and other telecommunication means.

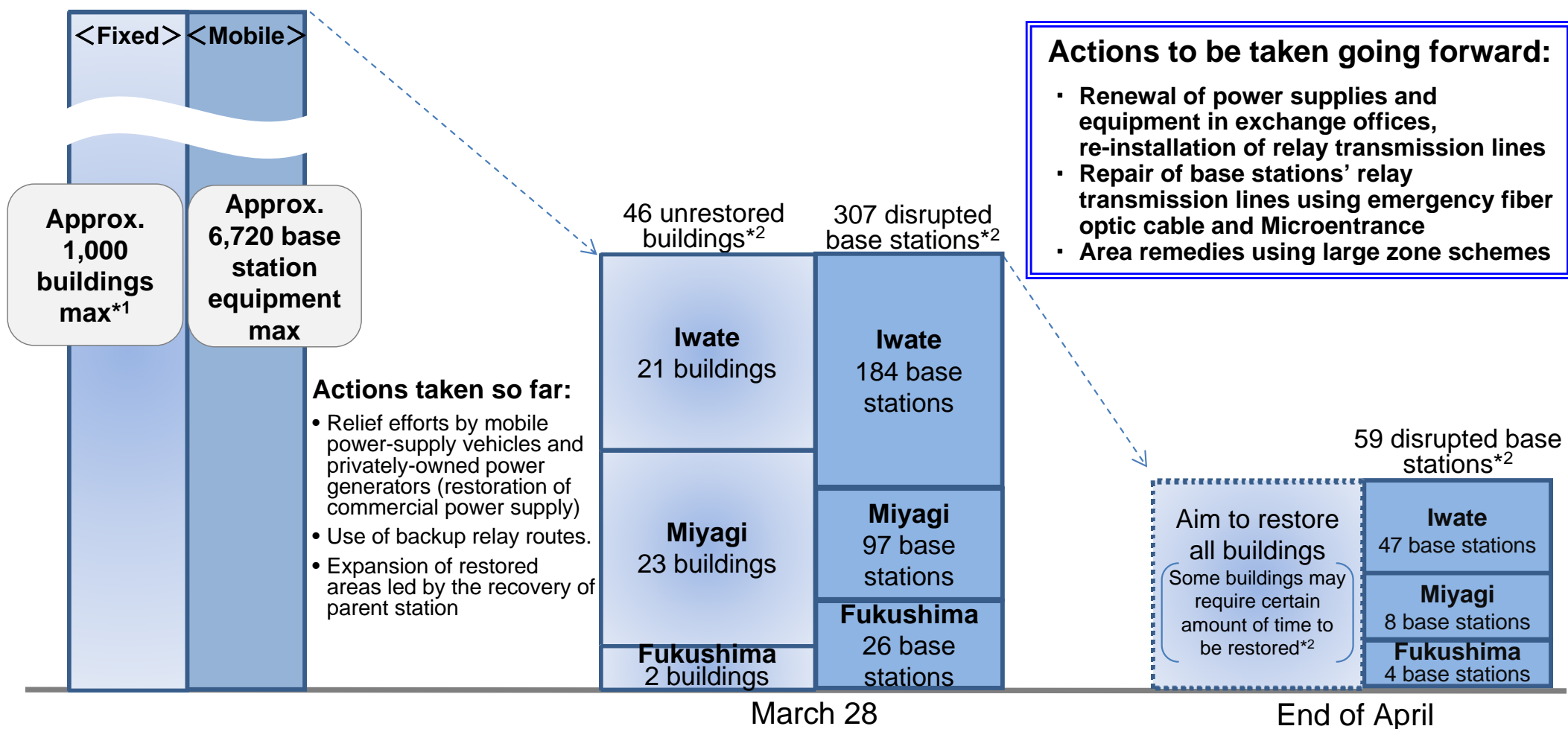

\*1 Number of buildings with commercial power supply disruptions and equipment failures due to the earthquake.

\*2 Excluding areas surrounding Fukushima Nuclear Power Plant (9 fixed-line service buildings and 68 mobile base stations).

# Main efforts in securing a means of communication

Securing a means of communication	Deployment of mobile base station vehicles (approx. 30 vehicles)
	Rental of free satellite mobile phones (approx. 870 handsets), mobile phones (approx. 1,440 handsets) and tablet PCs (approx. 180 terminals)
	Installation of special public telephones utilizing portable satellite equipment (approx. 2,300 telephones) Implemented to accommodate all requests from local governments
	Installation of free Internet stations (138 stations) Provided broadband environment through tie-ups with other companies as a means to gather information through the Internet
	Provision of free public wireless LAN (FLET'S SPOT, etc.) Provided free of charge for affected people and volunteers
Safety confirmation	Disaster Emergency Message Dial (approx. 3.17 million uses) Disaster Emergency Broadband Message Board (approx. 0.24 million uses) Disaster Message Board (approx. 3.79 million uses)
Life support	Provision of 43 company residences (approx. 3,000 houses) and 4 gymnasias Provided as living space for affected people upon the government's request
	Donation of 1 billion yen

\* Figures as of March 28, 2011