

# Capacity Deterioration Characteristics of Li-ion Batteries for Mobile Terminals

We propose a evaluation method of battery capacity deterioration characteristics in order to improve the quality of Li-ion batteries that provide power to mobile terminals and suggest user guidelines for optimal charging. We also examine factors causing capacity deterioration of Li-ion batteries. This research was conducted jointly with the Yamaki laboratory (Professor Jun-ichi Yamaki), Division of Advanced Device Materials, Institute for Materials Chemistry and Engineering, Kyushu University.

*Kazuhiko Takeno and Remi Shirota*

## 1. Introduction

The power consumption of mobile terminals is growing rapidly due to installation of video phone function, increased use of i-motion and i-appli brought about by introduction of pake-hodai, installation of applications supporting future digital TV functions and so forth. Currently, the power required for these applications is supplied by Li-ion batteries. This type of batteries has higher energy density than Ni-Cd and Ni-MH batteries, and the increased usage of these batteries contributes significantly to the downsizing of current mobile terminals.

Ensuring the quality of Li-ion batteries is thus an important issue. As Li-ion batteries are used for extended periods of time, the voltage and capacity of the batteries decreased. This phenomenon is known as battery capacity deterioration. When battery deterioration occurs, the operation time of mobile terminals may be shortened, or they will suddenly become unusable. The capacity deterioration depends on the usage conditions of individual users such as usage frequency and time, and given the present circumstances, it is difficult to predict the deterioration period. Obviously, this is a factor that lowers the quality of battery-powered products, for instance leading to increased failure rates of mobile terminals. Moreover, the mechanism of battery capacity deterioration itself has not been investigated sufficient-

ly, and it is difficult to predict a battery's lifetime accurately under the present circumstances.

In this article, we propose a evaluation method of capacity deterioration of Li-ion batteries assuming actual operation conditions of mobile terminals (conditions under which users use mobile terminals) and validate the method by comparing with measurement data. Moreover, we conduct a material analysis and internal impedance analysis of various factors causing capacity deterioration, and show the ideas for lifetime prediction and detection method.

## 2. Batteries for Mobile Terminals and Battery Capacity Deterioration

Figure 1 shows a power supply system for use in mobile terminals [1]. When the mobile terminal battery is charged, AC power from a commercial power supply is converted to DC power via an AC adapter and then input into the mobile terminal.

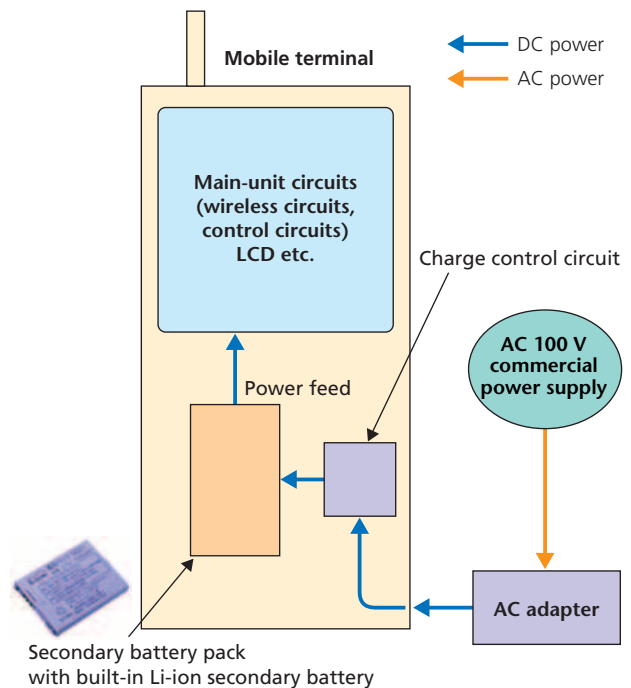

Figure 1 Power supply system for mobile terminals

nal. The power is stored in the Li-ion battery pack via a circuit that controls the charging of the battery pack. Meanwhile, when the mobile terminal is activated, power is supplied from the Li-ion battery to the main-unit circuits and used as a power source for making calls.

**Figure 2** shows discharge voltage curves obtained for repeated cycles of 100% charge and discharge. It is seen that the curve shows a tendency to decrease gradually as the number of cycles increases. **Figure 3** shows the charge-discharge cycle characteristics of batteries. It is seen that the battery capacity drops to half or less after approximately 800 cycles [2] [3].

Note that it is only possible to obtain battery lifetime data from repeated-cycle data such as the curves shown in Fig. 3; information about usage period and frequency is not available. A mobile terminal can be in various states, such as standby, calling and power-off modes, depending on which the operation status of the battery changes.

The causes of capacity deterioration of Li-ion batteries

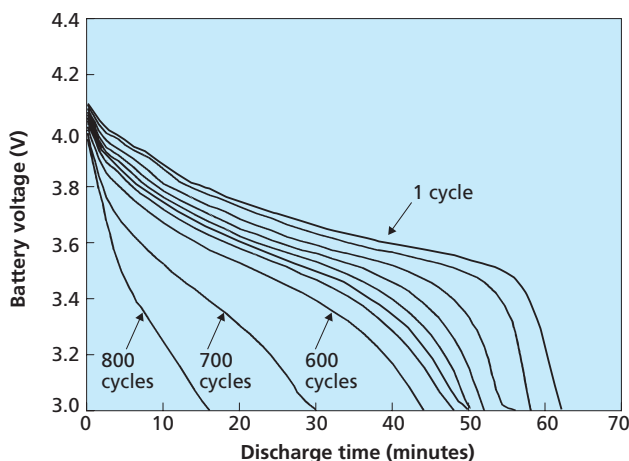

**Figure 2 Battery capacity deterioration (discharge voltage)**

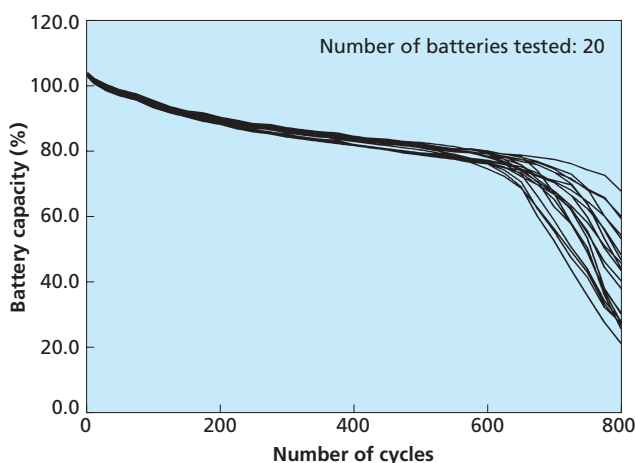

**Figure 3 Charge-discharge cycle characteristics of batteries**

include cycle deterioration and storage deterioration [4]. Cycle deterioration is a type of capacity deterioration that occurs when the charge-discharge cycles are repeated and depends on the number of cycles. Storage deterioration is a type of capacity deterioration that occurs to batteries in charged status and depends on the storage time from completion of charging to the start of discharge. Fig. 3 only shows cycle deterioration characteristics and does not reflect storage deterioration characteristics.

Thus, in order to fully understand the capacity deterioration characteristics of mobile terminal batteries, an evaluation method that takes both cycle and storage deterioration into account is required.

### 3. Examination of Battery Capacity Deterioration Considering Both Cycle and Storage Deterioration

We proposed an evaluation method for capacity deterioration reflecting both cycle and storage deterioration and conducted tests based on the proposed method. The mobile terminal and battery states are shown in **Figure 4**. The status of the battery changes from charge to discharge and then stop (rest) as the status of the mobile terminal changes from charge to call and then standby. The parameters of the Li-ion battery, such as charge interval ( $T_s$ ), Depth Of Discharge (DOD), rest, State Of Charge (SOC) and so forth, change according to the status of the mobile terminal. Among these parameters, DOD indicates the percentage of the battery capacity discharged from the full-charge status and is in proportion to call time ( $T_a$ ). Rest is a period where neither discharge nor charge is occurring.

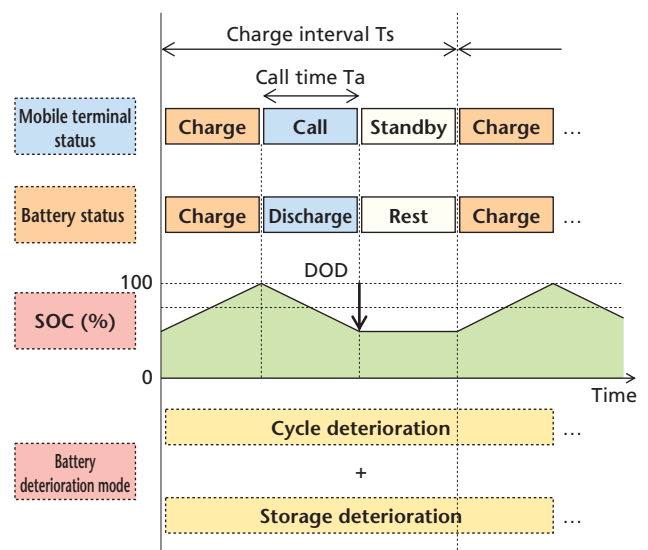

**Figure 4 States of mobile terminal and battery**

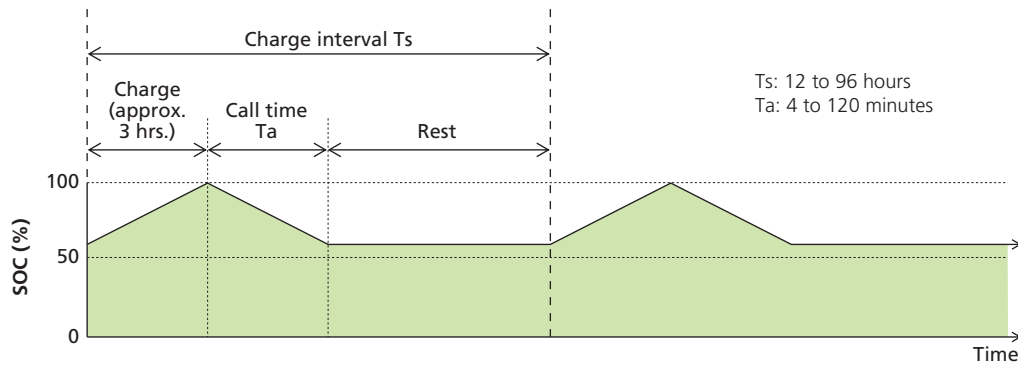

Figure 5 Test conditions of battery capacity deterioration characteristics

Figure 5 shows the conditions for testing the deterioration characteristics of the battery capacity based on the battery states above. We measured changes in the battery capacity by changing three parameters, call time ( $T_a$ ), charge interval ( $T_s$ ) and SOC. The batteries used are commercially available Li-ion battery packs for mobile terminals, which were evaluated in a temperature-based acceleration test (using a test temperature of 60 °C). The call time ( $T_a$ ) was varied from 4 minutes to 120 minutes and the charge interval ( $T_s$ ) was varied from 12 hours to 96 hours.

Figure 6 shows an example of the test results. It shows the status of capacity deterioration of a Li-ion battery after a year has passed. Two significant points can be observed from the data: the capacity deterioration is larger if the call time ( $T_a$ ) is short (smaller DOD) and the capacity deterioration is smaller if the charge frequency is low (longer charge interval ( $T_s$ )). The effect of the former point is that the influence of storage deterioration becomes large because a high degree of SOC remains if the amount of discharge is small. On the other hand, the effect of the latter point is that the influence of cycle deterioration becomes small, since long charge intervals correspond to a small number of cycles [5].

Based on the observations above, the results of examining the capacity deterioration characteristics of Li-ion batteries can be formulated as follows from the viewpoint of the mobile terminal user:

- The battery capacity deterioration tends to be smaller in case of heavy mobile terminal users (users who make calls often) than light mobile terminal users (users who do not make calls often).
- The battery capacity deterioration can be kept small if the mobile terminal is charged at two to three days intervals rather than charging frequently.

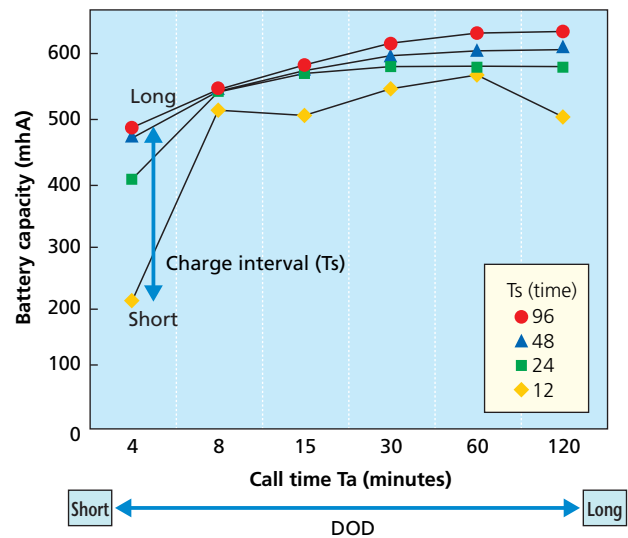

Figure 6 An example of test results (data equivalent to one year)

#### 4. Analysis of Battery Deterioration and its Application

We also conducted a material analysis to investigate the capacity deterioration of the Li-ion batteries presented in the previous chapter.

Figure 7 shows a pattern diagram of a cross-section of the Li-ion battery electrodes and a cross-section photo of an electrode taken by a Scanning Electron Microscope (SEM). Cycle and storage deterioration of the battery is said to be a reduction of the charge amount itself due to changes in the characteristics of the active materials in the electrode (reactants) and changes of the crystal structure. It is, however, also known that the internal resistance (impedance) of a battery changes as the battery deteriorates [3]. We therefore assumed that the deterioration advances as a Solid Electrolyte Interface (SEI) with low electric conductivity and ion conductivity develop on the surface of the electrodes (especially the anode) and analyzed the materials and

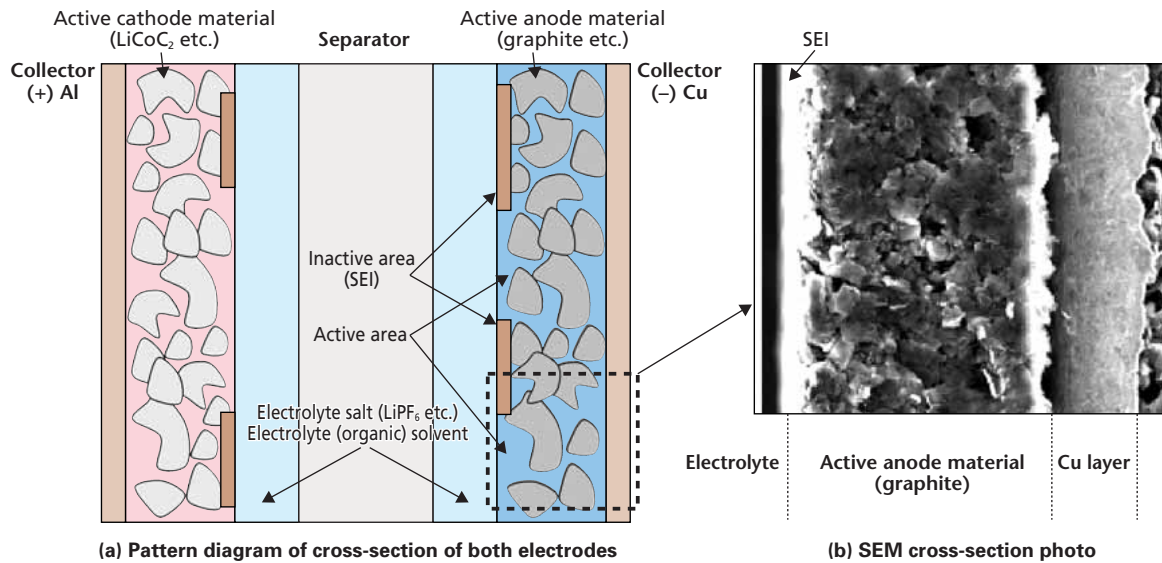

Figure 7 Battery analysis result

impedance characteristics during the process of battery deterioration accordingly.

**Figure 8** shows results of measuring the battery capacity deterioration and impedance (using a 1 kHz AC resistance). The graph shows results obtained in two types of charge states, 100% (fully charged) and 0% (fully discharged). From the result, it can be seen that the battery capacity and impedance are correlated, which supports the idea that development of SEI mentioned above is one of the causes of battery deterioration. Moreover, from the comparison between the two charge states, 100% (fully charged) and 0% (fully discharged), it is noted that the correlation between battery capacity and impedance is not influenced by the charge status of batteries.

It is considered to apply the data in battery checkers (instantaneous capacity deterioration judgment devices), which measure battery impedance, and use the regression formula of the data in Fig. 8 to estimate the battery capacity. Based on the results presented here, it is considered possible to check the battery capacities in any charge status brought in by users without recharging and so on, since the correlation between battery capacity and impedance is not influenced by the charge status of batteries.

## 5. Conclusion

This article proposed an evaluation method for capacity deterioration of Li-ion batteries assuming actual user operation conditions of mobile terminals and succeeded in identifying the capacity deterioration characteristics according to users' usage

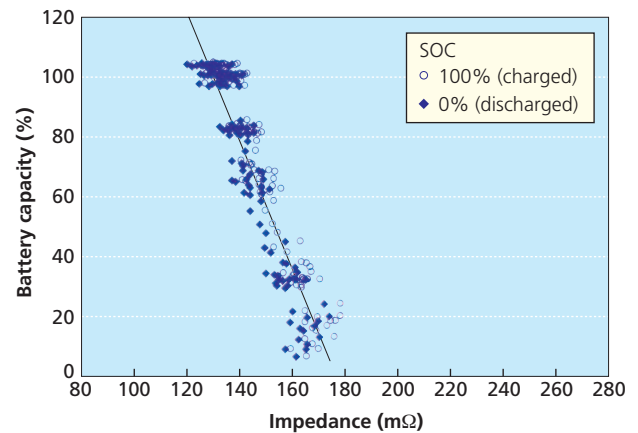

Figure 8 Battery capacity deterioration and impedance measurement result

conditions. Moreover, we analyzed the battery materials with respect to the causes of battery capacity deterioration and were able to suggest possibilities of battery lifetime prediction and battery checkers.

In the future we intend to investigate lifetime evaluation methods to be applied to new-type Li-ion batteries (using new cathode materials), which are actively being implemented lately, as well as whether the method can be applied to battery pack instantaneous capacity deterioration judgment devices, which are useful when operating mobile terminals.

## REFERENCES

- [1] K. Takeno, et al: "Evaluation Technology for Terminal Batteries," NTT DoCoMo Technical Journal, Vol. 10, No. 2, pp.42-46, Jul. 2002 (in Japanese).
- [2] K. Takeno, M. Ichikawa, K. Takano and J. Yamaki: "Methods of energy

conversion and management for commercial Li-ion battery packs of mobile phones,” IEICE Transaction on Communications, No. 12, pp. 3430–3436, 2004.

- [3] K. Takeno, M. Ichimura, K. Takano, J. Yamaki and S. Okada: “Quick Testing of Batteries in Lithium-ion Battery Packs with Impedance-Measuring Technology,” *Journal of Power Sources*, Vol. 128, pp. 67–75, 2004.
- [4] S. S. Choi and H. S. Lim: “Factors that affect cycle-life and possible degradation mechanisms of a Li-ion cell based on  $\text{LiCoO}_2$ ,” *Journal of Power Sources*, Vol. 111, pp.130–136, 2002.
- [5] K. Takeno, M. Ichimura, K. Takano and J. Yamaki: “Influence of Battery Cycle Deterioration and Storage Deterioration for Li-ion Battery using Mobile Phone,” *Journal of Power Sources*, Vol. 142, pp. 298–305, 2005.

#### ABBREVIATIONS

DOD: Depth Of Discharge  
SEI: Solid Electrolyte Interface  
SEM: Scanning Electron Microscope  
SOC: State Of Charge