

RoF Equipment Developed for Coverage in Small Areas where Received Power is Low

We have developed an RoF system to provide cellular services in areas where received power is low, such as in buildings. This system uses optical transmission lines to connect a base station to antennas, transmits 2 GHz band mobile RF signals with MIMO, and uses digital optical transmission technology to convert RF signals into digital light signals. This low-noise system can transmit RF signals from a single base station to a maximum of 16 hub units each with eight remote units connected in a double-star configuration to provide cost-effective service to small areas where received power is low.

Radio Access Network Development Department

Yasushi Ito

Yasuhiro Inada

Yutaka Fuke

1. Introduction

In recent years, mobile telephones have become a necessity of everyday life. Users are constantly demanding expanded service areas, and to improve user convenience, these demands must be met. Radio over Fiber (RoF) equipment that transmits RF signals over optical fiber provides service to areas where downlink signal received power is low, such as in buildings, underground shopping malls or tunnels [1][2].

Until now, most of the indoor equipment installed for low received power areas in buildings has been

designed for large-scale facilities with large traffic, in which a base station and RoF equipment are installed to distribute RF signals via many antennas throughout a building.

Conventional methods of providing high throughput in small-scale areas entail installing large numbers of base and remote units in various locations, which makes installation and operation expensive and difficult. To solve this issue, we have developed a long distance digital-optical MIMO^{*1}-compatible RoF system that can aggregate multiple small-coverage areas with hub units. This is an improved low noise system that can connect many remote

units to a base unit.

This article describes an overview of our new RoF system.

2. Direct Optical Modulation and Digital Optical Transmission Systems

To increase uplink (from remote units to base stations) received sensitivity in particular, we have adopted a system that digitizes RF signals and retransmits them as digital optical signals.

The Carrier to Noise Ratio (CNR)^{*2} of the direct optical intensity modulation commonly used for RoF equipment (**Figure 1(a)**) to modulate Laser Diode (LD) light intensity with RF signals is

©2013 NTT DOCOMO, INC.

Copies of articles may be reproduced only for personal, noncommercial use, provided that the name NTT DOCOMO Technical Journal, the name(s) of the author(s), the title and date of the article appear in the copies.

*1 **MIMO**: Multiple Input Multiple Output. A wireless communication technique that utilizes multiple paths between multiple antennas at the transmitting and receiving ends to exploit spatial propagation properties, causing the capacity of wireless links to increase proportionally to the number of antennas.

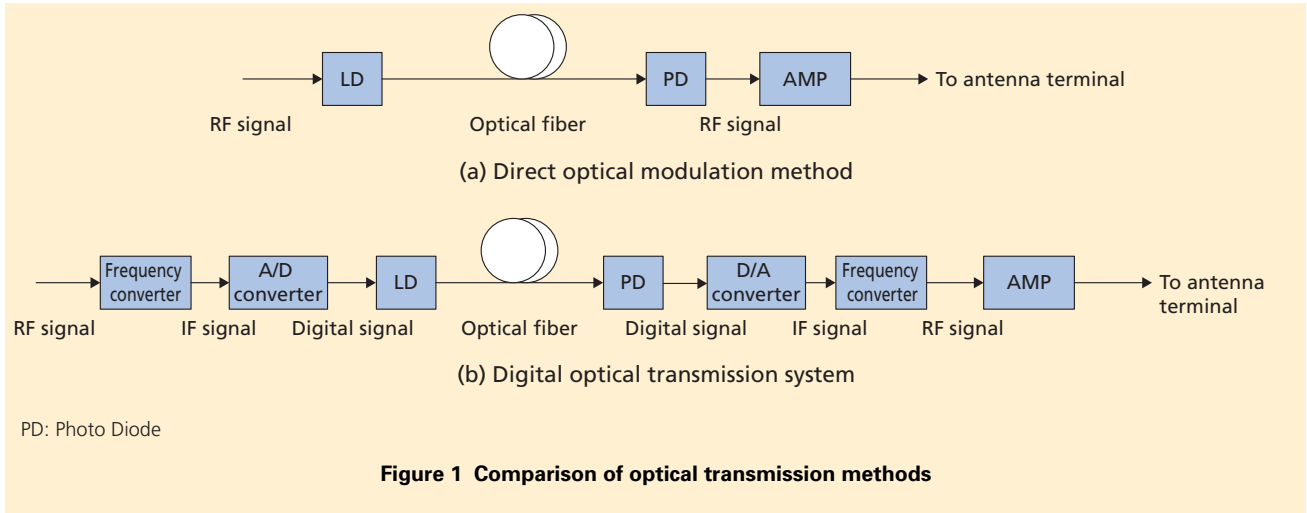

shown below [3].

$$CNR = \frac{(K_{PD} m P_{opt})^2 R_L}{2N} \quad (1)$$

$$N = N_{opt} + N_{sh} + N_{th} \quad (2)$$

$$N_{opt} = RIN (K_{PD} N_{opt})^2 R_L \cdot BW \quad (3)$$

$$N_{sh} = 2e K_{PD} P_{opt} R_L \cdot BW \quad (4)$$

$$N_{th} = 4kT \cdot NF \cdot BW \quad (5)$$

Where;

P_{opt} : Optical received power [W]

R_L : Load [Ω]

BW : Radio system bandwidth [Hz]

e : The electric charge 1.6e-19[C]

RIN ^{*3} : Relative optical Intensity Noise [1/Hz]

K_{pd} : Photo detector conversion efficiency [A/W]

k : The Boltzmann constant

T : Absolute temperature [K]

NF : Optical receiver circuit Noise

Figure^{*4}

N_{sh} : Shot noise^{*5}

To ensure a high *CNR* for high received sensitivity in conventional systems, signal levels must be maintained with a high optical modulation index^{*6} (*m*) while minimizing the optical intensity noise (N_{opt}) and thermal noise^{*7} (N_{th}) components of the noise power. A low-noise LD must therefore be adopted to reduce N_{opt} . However, because a high modulation index can cause distortion in LDs and degrade the Adjacent Channel Leakage power Ratio (ACLR)^{*8} and modulation accuracy^{*9}, the modulation index *m* must be maintained at 20% or below.

We have set $NF=16$ dB for uplinks, the same performance level as conventional equipment. To set maximum RF signal input power at -27 dBm (decibel-milliwatt)^{*10}, the *CNR* must be 65 dB/3.84 MHz or greater. **Table 1** describes conditions at each section of device. To achieve the target *CNR*, *RIN* must be -160 dB/Hz, and modulation index *m* must be 12%. LDs with these

characteristics are often expensive optical devices such as Distributed Feed Back LDs (DFB-LD)^{*11}.

By contrast, if the digital signal is transmitted optically as shown in Fig. 1(b), the *CNR* is determined by the A/D converter resolution^{*12}. Thus, there is no need for expensive low-distortion, low-*RIN* optical components, as low-cost optical devices can be used to transmit digital signals.

The following equation describes the *CNR*, where *N* is the A/D converter resolution, and f_s is the sampling frequency [4].

$$CNR = 6.02N + 1.76 + 10 \log \left(\frac{f_s}{2BW} \right) \quad (6)$$

In this system, the maximum input power is at or below -27 dBm and $NF=16$ dB (noise: -92 dBm/3.84 MHz) with the target *CNR* at 65 dB/3.84 MHz. The A/D converter resolution *N* must be 10 bits for a sampling frequency f_s of 82 MHz, to satisfy equation (6). To transmit a 20 MHz bandwidth sig-

*2 **CNR**: The ratio of noise power to carrier power.

*3 **RIN**: A type of noise that occurs with optical components (e.g. LDs and LEDs), and is proportional to the intensity of light.

*4 **Noise Figure**: A comparison of input and

output signal CNRs.

*5 **Shot noise**: Noise caused by fluctuations in the number of photons.

*6 **Optical modulation index**: The ratio of RF signal power to light power when RF signals are transmitted with a direct optical modulation

system used to modulate the intensity of light at optical elements such as LDs.

*7 **Thermal noise**: Noise that occurs due to the thermal motion of free electrons.

nals in the 2 GHz band, 820 Mbit/s (82 MSPS x 10 bits) is required for the optical transmission speed. To transmit two signals on a single optical fiber with MIMO, the system transmission speed has to be 1.64 Gbit/s (820 Mbit/s x 2) or more.

3. System Features

(1) Digital Optical Transmission

To achieve low-noise RF characteristics for long-distance optical transmission, the system uses a digital optical transmission system that converts RF signals to digital signals and transmits optical digital

signals as described in Chapter 2.

(2) Double-Star Configuration^{*13}

When servicing a large-size,

low received power area as described in **Figure 2** (a), a base station is required inside the build-

Table 1 Direct optical modulation system CNR and conditions at each section

Item	Value	Remarks
LD output P_t	30 mW	
LD relative intensity noise RIN	-160 dB/Hz	
Optical modulation index m	12 %	
Optical loss L_{OPT}	15 dB	Up to 20 km transmission distance Includes connector loss etc.
Optical received power P_{OPT}	1 mW	
PhotoDetector (PD) conversion efficiency K_{PD}	1 A/W	
NF (noise figure) of optical received circuit	1.5 dB	
Load R_L	50 Ω	
RF input power	-27 dBm	
RF output power	-27 dBm	
Target CNR	65 dB/3.84 MHz	Equivalent to $NF = 16$ dB for overall system

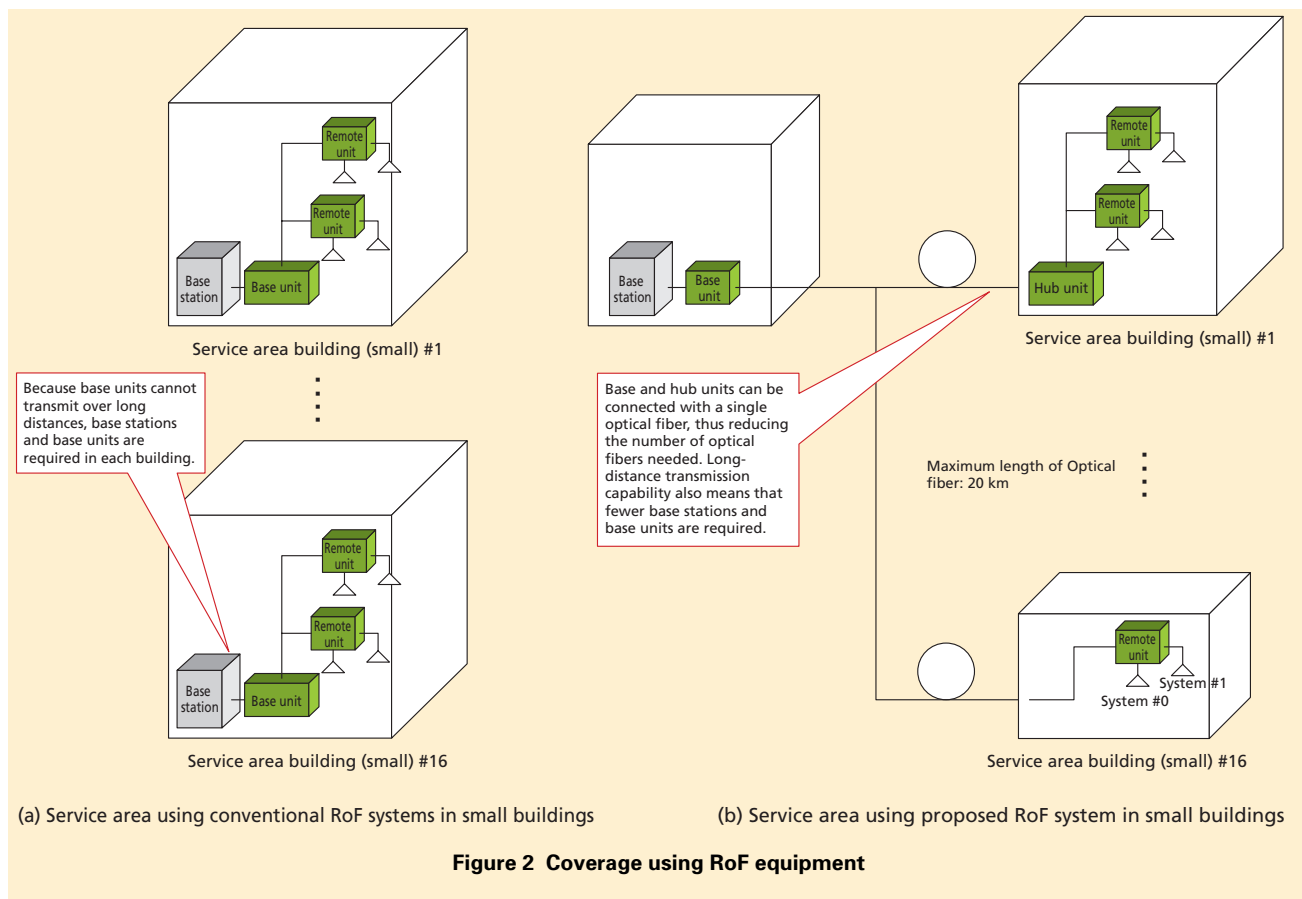

*8 **ACLR**: In modulated signal transmission, the ratio between the transmitted signal band power and undesired power generated in the adjacent channels.
 *9 **Modulation accuracy**: The accuracy of the IQ component of modulated signals.

*10 **dBm**: Power value [mW] expressed as $10 \log(P)$. The value relative to a 1 mW standard (1 mW=0 dBm).
 *11 **DFB-LD**: Distributed feedback laser diode.
 *12 **Resolution**: In this article, this indicates the number of bits used by A/D, D/A converters.

*13 **Double-star configuration**: A configuration in which three types of units are connected, e.g. units A, B and C. Several B units are connected in a radial pattern to an A unit, and then a number of C units are connected in a radial pattern to each B unit.

ing, because conventional systems cannot transmit over the long-distances between the base and remote units. By contrast, Fig. 2 (b) describes a double-star configuration in which hub units are connected to a base unit in a star configuration with remote units subsequently connected to each hub unit in star configurations. By increasing transmission distance between base units and hub units, this cost-effective system only needs a single base station to service small-scale low received power areas in multiple buildings or underground facilities. Optical fiber maintenance costs can also be reduced, since the base unit is connected to each hub unit with a single optical fiber.

This system enables connection of up to 128 remote units. Therefore, to provide coverage, we selected the A/D converter resolution and sampling frequency to improve received sensitivity with 0 dB uplink gain^{*14} and less than 16 dB NF when one remote unit is connected.

If N remote units are installed, NF is $16 + 10\log(N)$. If the maximum 128 remote units are installed, NF is 37 dB or less.

(3) MIMO Compatibility

This system converts LTE MIMO signals in the 2 GHz band into digital signals, and enables transmission over a single optical

fiber by time-multiplexing the digital signals.

MIMO RF signals are amplified by Power Amplifiers (PAs)^{*15} on each branch and then transmitted to antennas.

4. System Configuration

With this system, it is possible to connect a maximum of 16 hub units to one base unit and a maximum of eight remote units to each hub unit. Hub and remote units installed in buildings that contain low received power areas, and by feeding RF signals from remote units to a base unit, one base station can provide service to multiple in-building areas as a single sector.

Figure 3 describes the configuration of this system. Downlink RF signals from the base station are converted to IF^{*16} signals via a frequency converter, and then IF signals are converted to digital signals by an A/D converter. Undesired frequency components are filtered^{*17} by a digital processor, and after multiplexing MIMO signals for systems #0 and #1, signals are converted to optical signals by an E/O, O/E converter^{*18}. Base and hub units are connected with an optical fiber. A hub unit receives optical signals from its base unit and distributes the signals to the various remote units connected to it, and also temporarily converts optical signals from the various remote units to electricity, digitally combines those signals, and then re-converts them to opti-

cal signals to be transmitted to the base unit. After the optical signals have been converted to electrical signals by the remote unit E/O, O/E converter, they are split for MIMO systems #0 and #1, and converted into RF signals by D/A and frequency converters. These signals are then amplified by a PA and sent to the antenna terminal through a duplexer^{*19}.

In remote units, RF signals from mobile phones are converted by a frequency converter and then by an A/D converter. Filtering and other operations are performed by a digital processor. The E/O, O/E converter then converts the signals into optical signals, which are then transmitted to hub units.

Base units convert signals into MIMO RF signals (for systems #0, #1) with an E/O, O/E converter and digital processor, and transmit them to the base station.

5. Equipment Specifications

The external appearance of the equipments can be seen in **Figure 4**. Since hub and remote units will most likely be installed above ceilings or other narrow spaces, they have been designed for compactness, low power consumption and passive cooling. These units have also been designed for installation both in flat spaces or hanging on walls.

Equipment specifications are

*14 **Gain:** The power increase ratio of amplifier input power to output power.

*15 **PA:** Electronic circuitry to amplify a signal to the output power required for communications.

*16 **IF:** Intermediate frequency.

*17 **Filtering:** Processing where the relative magnitudes of input signal frequency components are modified before output.

*18 **E/O, O/E converter:** Converts electrical signals into optical signals and vice-versa.

*19 **Duplexer:** A device that consisting of a transmitter filter and receiver filter. It allows a single antenna to be used for both transmission and reception.

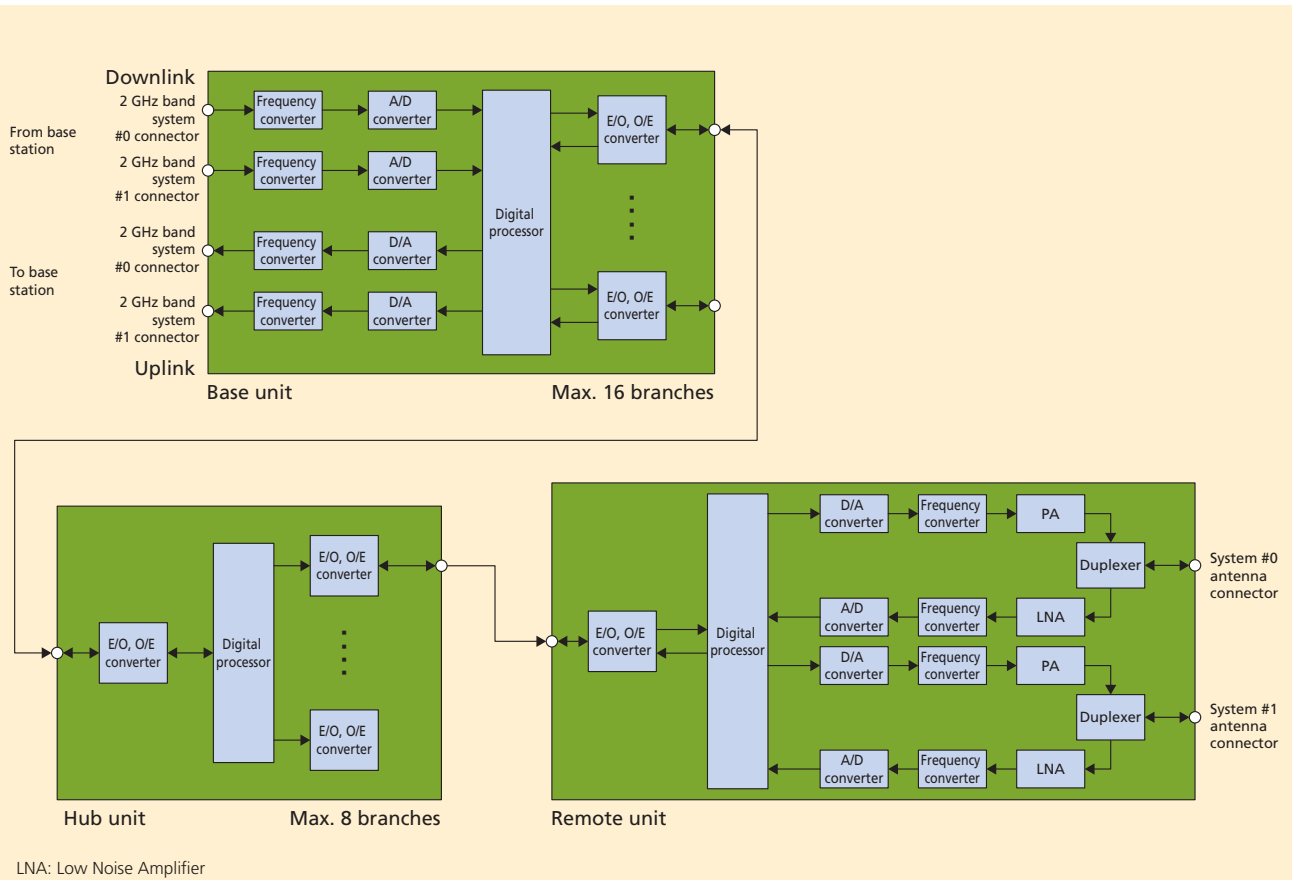

Figure 3 MIMO-compatible RoF system configuration



(a) Base unit



(b) Hub unit



(c) Remote unit

Figure 4 Equipment appearance

described in **Table 2**. Downlink output power is 16 dBm per branch, while 20 MHz bandwidth signals in the 2 GHz

band can be transmitted and received. Output power deviation, ACLR and spurious emissions^{*20} are satisfied for

technical standards (W-CDMA, LTE) [5] [6]. **Figure 5** describes the 2 GHz band downlink ACLR for this system.

*20 **Spurious emission:** An undesired signal that appears out of band when a signal is transmitted.

Table 2 Equipment specifications

Item	Downlink	Uplink
Transmitted bandwidth	2,130 – 2,150 MHz	1,940 – 1,960 MHz
Input power	-9 dBm/total/branch	-27 dBm/branch
Output power	16 dBm/total/branch	-27 dBm/branch
ACLR	-45.8 dBc or lower	
Noise Figure		16 dB or lower (with one slave), 37 dB or lower (with 128 slaves)
No. of hub units	Max. 16 units	
No. of remote units	Hub unit- remote unit: Max. eight units, total units: Max. 128 remote units	
Power supply	Base units: -48 V, hub unit, remote units: AC100 V	
Optical transmission distance	Base unit – hub unit: Max 20 km, hub unit - remote unit: Max. 4 km	

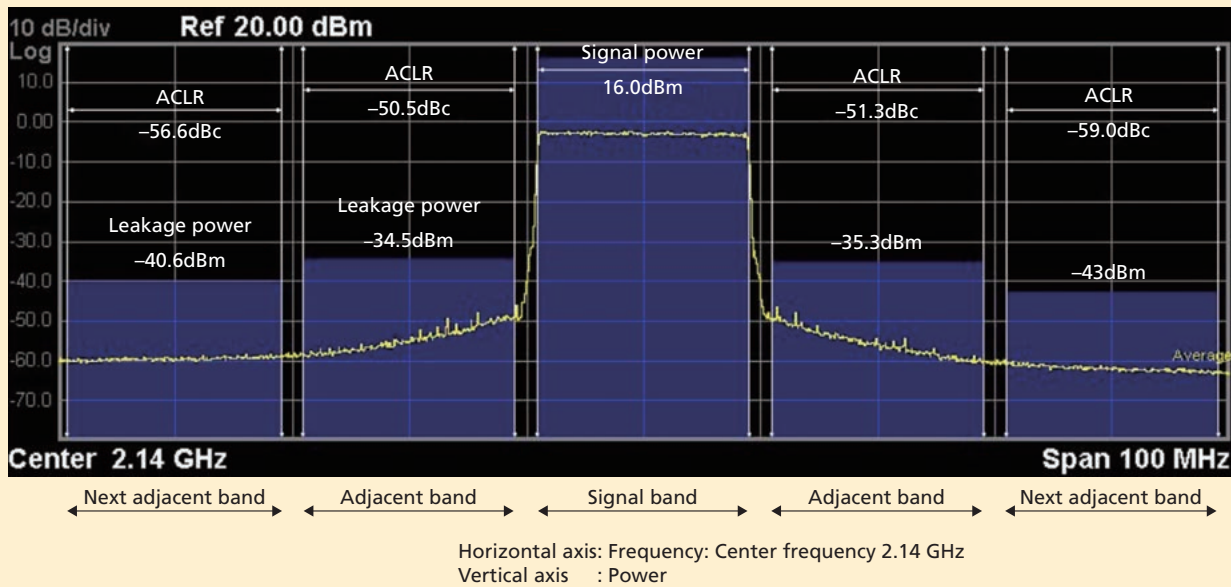

After transmitting the 20 MHz bandwidth RF signal in the 2 GHz LTE band, ACLR achieves -49 dBc (decibels relative to the carrier)^{*21} at 18 MHz (-33 dBm/18 MHz) or lower.

The maximum optical fiber distance between base and hub units is 20 km, while the maximum distance between hub and remote units is 4 km. Hub and

remote units are supplied by AC100 V commercial power.

6. Conclusion

In this article, we have described an MIMO-compatible RoF system designed for efficient deployment and service in low received power areas inside buildings and similar locations.

In subsequent research, we will study ways to expand the number of remote units and develop equipment to transmit multi-band RF signals.

REFERENCES

- [1] Y. Ito and Y. Ebine: "Optical fiber link for transmitting 3rd generation mobile communication system (IMT-2000)," OCS99-125, pp. 13-18, Mar. 2000 (in Japanese).

*21 dBc: Level relative to the carrier signal.

- [2] A. Hikuma et al.: "Radio Base Stations Equipment toward Economical Expansion of FOMA Coverage Areas," NTT DOCOMO Technical Journal, Vol. 6, No. 1, pp. 52-59, Jun. 2004.
- [3] J. Namini, M. Shibutani, W. Domon, T. Kanai and K. Emura: "Optical Feeder Basic System Design for Microcellular Mobile Radio," IEICE Trans. Commun., Vol. E76-B, No. 9, Sep. 1993.
- [4] Y. Sugimoto and A. Matsuzawa: "Latest analog to digital conversion technology," Mimatsu Data System, pp. 18-23, 1994 (In Japanese).
- [5] TELEC T-112: "Characteristics test method for DS-CDMA/T-HCDMA mobile radio communication base stations, etc" (In Japanese).
- [6] TELEC T-146: "Characteristics test method for SC-FDMA mobile radio communication base stations, etc" (In Japanese).