

Special Articles on SAE Standardization Technology

Basic SAE Management Technology for Realizing All-IP Network

The standardization of 3GPP Release 8 brings new provisions for All-IP networks that realize high speed, high-capacity packet communications for mobile communications services. It also accommodates various radio access systems such as LTE, which will enrich packet services in the future. This type of network is called EPC, and it is able to achieve features such as high-quality handover between different radio access systems and flexible packet transmission management by optimizing for packet switching and introducing IP technology. This provides major advancements over earlier packet switching networks.

Core Network Development Department **Katsutoshi Nishida**
Itsuma Tanaka
Takashi Koshimizu

1. Introduction

NTT DOCOMO has proactively contributed and made proposals for the realization of an All-IP Network (AIPN) that will form a common, IP-based core network since the 3rd Generation Partnership Project (3GPP) began considering it in June 2004, starting with the study of requirements to completion of the System Architecture Evolution (SAE) standardization[1]. An AIPN will make it possible to further develop packet services in the future with

improvements such as increased radio capacity, while achieving the earlier requirements of mobile network operators.

Evolved Packet Core (EPC), for which specifications were completed with standardization of 3GPP Release 8 SAE, is a common core network that accommodates not only the radio access systems specified by the 3GPP, such as Long Term Evolution (LTE) and 3G, but also various other access systems such as Wireless LAN (WLAN), WiMAX, and even the

3GPP2^{*1} radio access systems [2][3]. More specifically, the mobility management^{*2} and QoS management^{*3} functions provided by the core network do not depend on the radio access system, and are implemented using a common mechanism. Also, with EPC, general IP-based protocols are adopted to provide these types of functions, which allow it to achieve the high commonality, a goal of the AIPN [4][5], while satisfying the requirements of mobile operators. EPC is an architecture that can be widely used, not only for 3GPP operators,

*1 **3GPP2**: A Third-Generation Mobile Communication System (3G) standardization project that is standardizing the cdma2000 technical specifications, which are part of the IMT-2000 specifications.

*2 **Mobility management**: Management technology that enables uninterrupted initiating and receiving of calls and communications even when its connection to the core network changes, as when changing radio systems.

but also for a variety of mobile and fixed operators [6], through implementation with general IP-based technology.

In this article, we give an outline of the functional entities and network architecture of EPC, which accommodates the 3GPP radio access systems, LTE and 3G. We also describe the functional characteristics and the basic management technologies of EPC.

2. EPC Architecture for Accommodating LTE and 3G

The network architecture of EPC, focusing on accommodation of LTE and 3G, is shown in **Figure 1**. EPC networks are composed of core network components, LTE radio access networks, and 3G radio access networks. The core network consists mainly of components that do not depend on the radio access method, including Serving-Gateways (S-GW), Packet Data Network-Gateways

(P-GW) and the Policy and Charging Rules Function (PCRF). LTE radio access networks consist of Mobility Management Entities (MME) and eNodeBs^{*4}, while 3G radio access networks consist mainly of Serving General Packet Radio Service Support Nodes (SGSN) and Radio Network Controllers (RNCs) /NodeBs.

The S-GW is a serving packet gateway that accommodates LTE and 3G, handles transmission of user data, and acts as the point for switching between LTE and 3G radio access networks.

The P-GW is the connection point with the Packet Data Networks (PDNs) outside of the core network, such as the network providing i-mode or the IP Multimedia Subsystem (IMS), which provides Voice over IP (VoIP) and other multimedia services. It accommodates 3GPP and non-3GPP radio access systems and performs operations such as allocating IP addresses.

The PCRF is the component which

determines the policies for policy management^{*5} such as QoS and charging rules, which are then applied by the P-GW and S-GW. The P-GW and S-GW enforces the policy for each packet based on information received from the PCRF.

The MME handles mobility management for mobile terminals (hereinafter referred to as “terminals”) in the LTE radio access system, as well as authentication (security management), and processing to control the user data transmission path between S-GW and eNodeB. The MME is a functional entity that performs signal control only, and does not actually transmit user data. For mobility management, the MME can manage location registration in cooperation with the SGSN in order to improve the efficiency of location registration when terminals move between LTE and 3G radio areas, as described below.

Like the MME, the SGSN handles mobility management for terminals in the 3G radio access system, including authentication (security management), and setting up the communications path allowing continuous communication when switching between LTE and 3G radio access systems. Specifically, when a dual LTE/3G terminal is in a 3G radio area, the SGSN sets up the communications path to the S-GW [7].

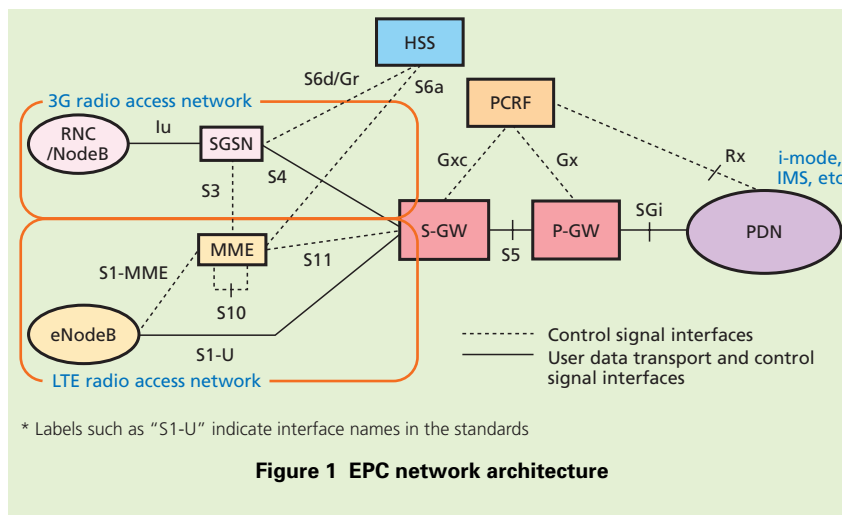

*3 **QoS management:** Technology managing transmission quality by, for example, prioritizing transmission of packets.

*4 **eNodeB:** A base station for the LTE radio access system.

*5 **Policy management:** Technology for managing communications, such as QoS or packet transmission permissions, based on network and subscriber information.

3. Overview of EPC Functional Characteristics and Basic Management

EPC optimizes packet switching functions with new features such as an always-on connection function which reduces processing time for initiating and receiving communications, an implementation of handover management able to switch paths rapidly and without packet loss, and reduced signaling for location registration when switching between LTE and 3G radio access systems. It also uses IP technology to implement simple mobility management and flexible policy management.

3.1 Network Management with Always-on Connections

With EPC, when a terminal connects to the LTE radio access system it is automatically connected to the PDN and this connected state is maintained continuously. In other words, as the terminal is registered on the network (attached^{*6}) through the LTE radio access system, a communications path to the PDN (IP connectivity) is established. The PDN to which a connection is established can be preconfigured on a per-subscriber basis, or the terminal can specify it during the attach procedure. This PDN is called the default PDN.

With the always-on connection function, the radio link of the connection only is released after a set amount of time has elapsed without the terminal

performing any communication, and the IP connectivity between the terminal and the network is maintained. By doing this, only the radio link needs to be reconfigured when the terminal begins actual communication, allowing the connection-delay time to be reduced. Also, the IP address obtained when the terminal attaches can be used until it detaches^{*7}, so it is always possible to receive packets using that IP address.

The information flow for the terminal attaching to the network up until the

connection to the PDN is established is shown in **Figure 2**.

- Steps (1) to (3):
When the terminal establishes a radio control link for sending and receiving control signals with the eNodeB, it sends an attach request to the MME. The terminal and MME perform the required security procedures, including authentication, encryption and integrity^{*8}.
- Steps (4) to (5):
The MME sends an update location request message to the

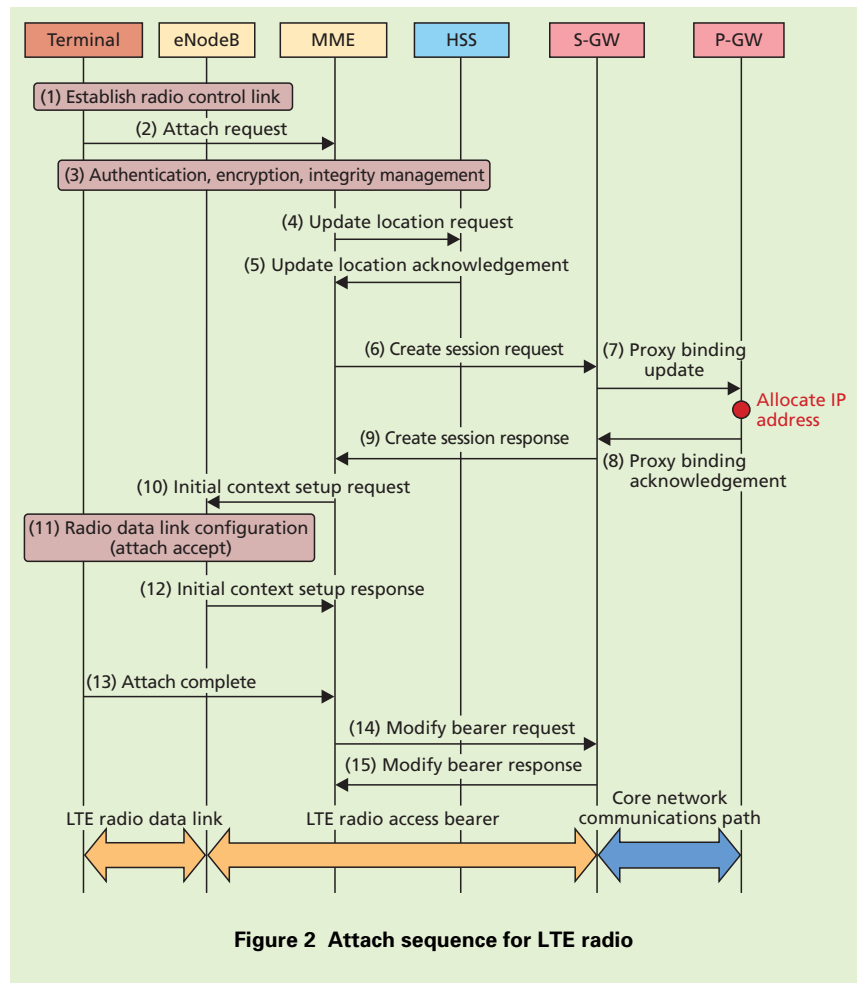

Figure 2 Attach sequence for LTE radio

*6 **Attach**: Procedure to register a terminal on the network when, for example, its power is switched on.

*7 **Detach**: Procedure to remove registration of a terminal from the network when, for example, its power is switched off.

*8 **Integrity**: Whether the transmitted data is complete and has not been falsified. Here we refer to pre-processing required to ensure integrity of the data.

Home Subscriber Server (HSS), and the HSS records that the terminal is connected under the MME.

- Step (6):

To begin establishing a transmission path to the default PDN, the MME sends a create session request to the S-GW.

- Steps (7) to (8):

When the S-GW receives the create session request from the MME, it requests proxy binding update to the P-GW. The P-GW allocates an IP address to the terminal and notifies the S-GW of this information in a proxy binding acknowledgement message. This process establishes a continuous core-network communications path between the P-GW and the S-GW for the allocated IP address.

- Step (9):

The S-GW prepares a radio access bearer^{*9} from itself to the eNodeB, and sends a create session response signal to the MME. The create session response signal contains information required to configure the radio access bearer from the eNodeB to the S-GW, including information elements issued by the S-GW and the IP address allocated to the terminal.

- Steps (10) to (11) and (13):

The MME sends the information in the create session response signal to the eNodeB in an initial context setup^{*10} request signal. Note

that this signaling also contains other notifications such as the attach accept, which is the response to the attach request.

When the terminal receives the attach accept in Step (11), it sends an attach complete response to the MME, notifying that processing has completed.

- Step (12):

The eNodeB establishes the radio data link and sends the attach accept to the terminal. It also configures the radio access bearer from the eNodeB to the S-GW and sends an initial context setup response to the MME. The initial context setup response contains information elements issued by the eNodeB required to establish the radio access bearer from the S-GW to the eNodeB.

- Steps (14) to (15):

The MME sends the information in the initial context setup response to the S-GW in a modify bearer request signal. The S-GW completes configuration of the previously prepared radio bearer from the S-GW to the eNodeB and sends a modify bearer response to the MME.

Through these steps, a communications path from the terminal to the P-GW is established, enabling communication with the default PDN.

If the terminal performs no commu-

nication for a set period of time, the always-on connection function described above releases the radio control link, the LTE radio data link, and the LTE radio access bearer, while maintaining the core network communications path.

After the terminal has established a connection to the default PDN, it is possible to initiate another connection to a different PDN. In this way it is possible to manage PDNs according to service. For example the IMS PDN, which provides voice services by packet network, could be used as the default PDN, and a different PDN could be used for internet access.

To establish a connection to a PDN other than the default PDN, the procedure is the same as the attach procedure shown in Fig.2, excluding Steps (4) and (5).

3.2 Handover between Different Radio Access Systems during Communication

1) Overview of Handover Operation

With EPC, continuous communication is possible, even while the terminal switches from one type of radio access system to another.

Specifically, in order to achieve the internal network path switching required to change radio access systems, the S-GW provides a mobility management anchor function^{*11} for handover between 3GPP radio access systems, and the P-GW provides the function for handover between 3GPP and

*9 **Bearer:** A logical transmission path established, as between the S-GW and eNodeB.

*10 **Context setup:** Configuration of information required for the communications path and communications management.

*11 **Anchor function:** A function which switches the communications path according to the area where the terminal is located, and forwards packets for the terminal to that area.

non-3GPP radio access systems. In this way, the IP address does not change when the terminal switches radio access systems, and communications can continue after handover.

In handover between the 3GPP radio access systems, LTE and 3G, handover preparation is done before changing systems, including tasks such as securing resources on the target radio access system, through cooperation between the radio access systems (**Figure 3** (a)(A)). Then, when the actual switch occurs, only the network path needs to be switched, reducing handover processing time (Fig.3 (a)(B)). Also, loss of data packets that arrive at

the pre-switch access point during handover can be avoided using a data forwarding function (Fig.3 (b)).

In this way, through interaction between radio access systems, fast handover without packet loss is possible, even between radio access systems such as LTE and 3G which cannot be used simultaneously.

2) Handover Preparation Procedure (Fig.3 (a)(A))

The handover preparation procedure for switching radio access from LTE to 3G is shown in **Figure 4**.

- Step (1):
The terminal sends a radio quality report containing the handover

candidate base-stations and other information to the eNodeB. The eNodeB decides whether handover shall be performed based on the information in the report, identifies the base station and RNC to switch to, and begins handover preparation.

- Steps (2) to (3):
The eNodeB sends a handover required to the MME, sending the RNC identifier and transmission control information for the target radio access system. The MME identifies the SGSN connected to the target RNC based on the received RNC identifier and sends the communication control and

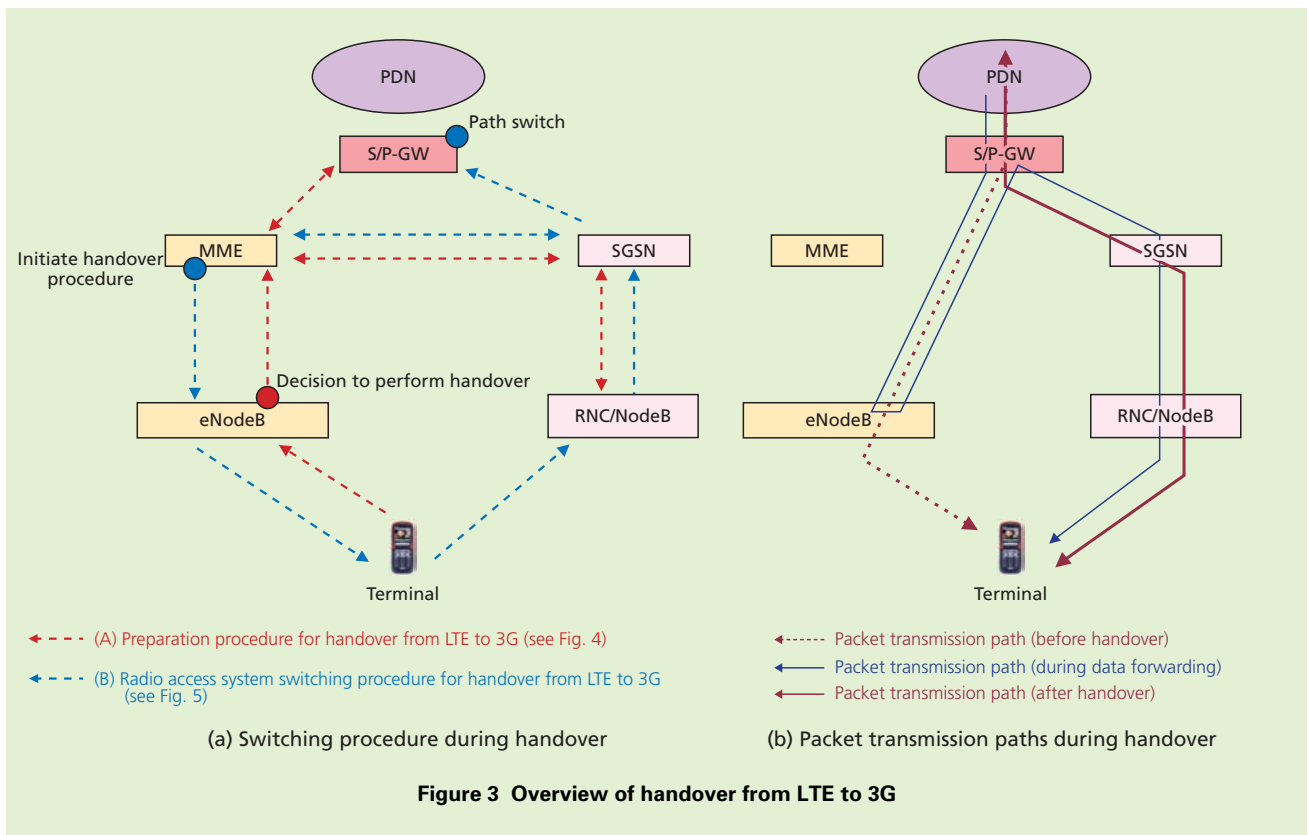

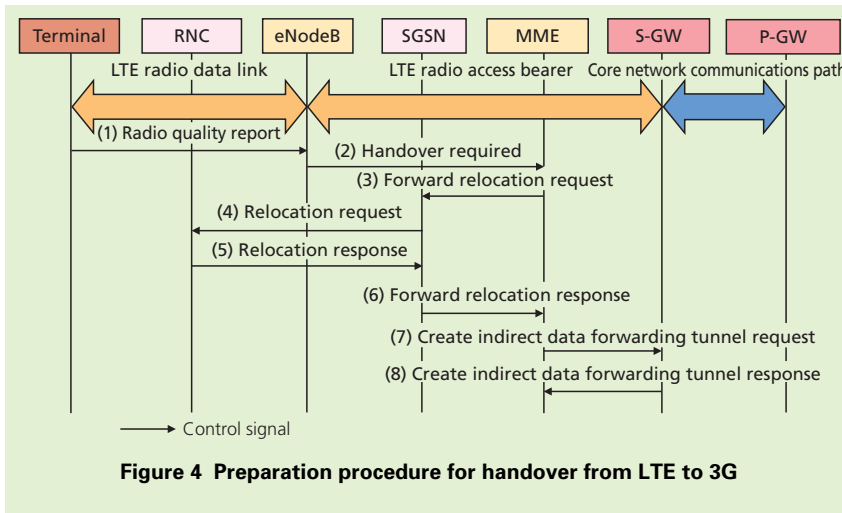

other information it received from the eNodeB to the SGSN in a forward relocation^{*12} request signal. The information required to configure the communications path between the S-GW and SGSN, which is used for data transmission after the MME has completed the handover, is sent at the same time.

- Steps (4) to (5):

The SGSN forwards the relocation request to the RNC, notifying it of the communications control information transmitted from the eNodeB. The RNC performs the required radio configuration processing based on the received information and sends a relocation response to the SGSN. Note that through this process, a 3G radio access bearer is prepared between the SGSN and RNC.

- Step (6):

The SGSN sends a forward relocation response to the MME in

order to notify it that relocation procedure has completed. This signal also includes data issued by the SGSN and required to configure a communications path from the S-GW to the SGSN, to be used for data forwarding.

- Steps (7) to (8):

The MME sends a create indirect data forwarding tunnel request to the S-GW, informing it of the information issued by the SGSN that it just received. From the information that the S-GW receives, it establishes a communications path from the S-GW to the SGSN for data forwarding and sends a create indirect data forwarding tunnel response to the MME.

Through this handover preparation, target 3G radio-access resources are readied, the radio access bearer between the SGSN and RNC is configured, and the data forwarding path from the

S-GW to the SGSN configuration is completed.

3) Handover Procedure for Radio Access System Switching (Fig. 3(a)(B)):

The handover process after switching radio access system is shown in **Figure 5**.

- Steps (1) to (2):

When the handover preparation described in Fig.4 is completed, the MME sends a handover command to the eNodeB. When it receives this signal, the eNodeB sends a handover from LTE command for the terminal to switch radio systems. Note that when the eNodeB receives the handover command from the MME, it begins forwarding data packets received from the S-GW. Thereafter, packets for the terminal that arrive at the S-GW are forwarded to the terminal by the path: S-GW, eNodeB, S-GW, SGSN, RNC.

- Steps (3) to (6):

The terminal switches to 3G and when the radio link configuration is completed, notification that it has connected to the 3G radio access system is sent over each of the links through to the MME: from terminal to RNC, from RNC to SGSN, and from SGSN to MME. This way, the MME can perform Step (10) described below to release the eNodeB resources after a set period of time has elapsed.

*12 **Relocation:** Switching communications equipment such as area switches during communication.

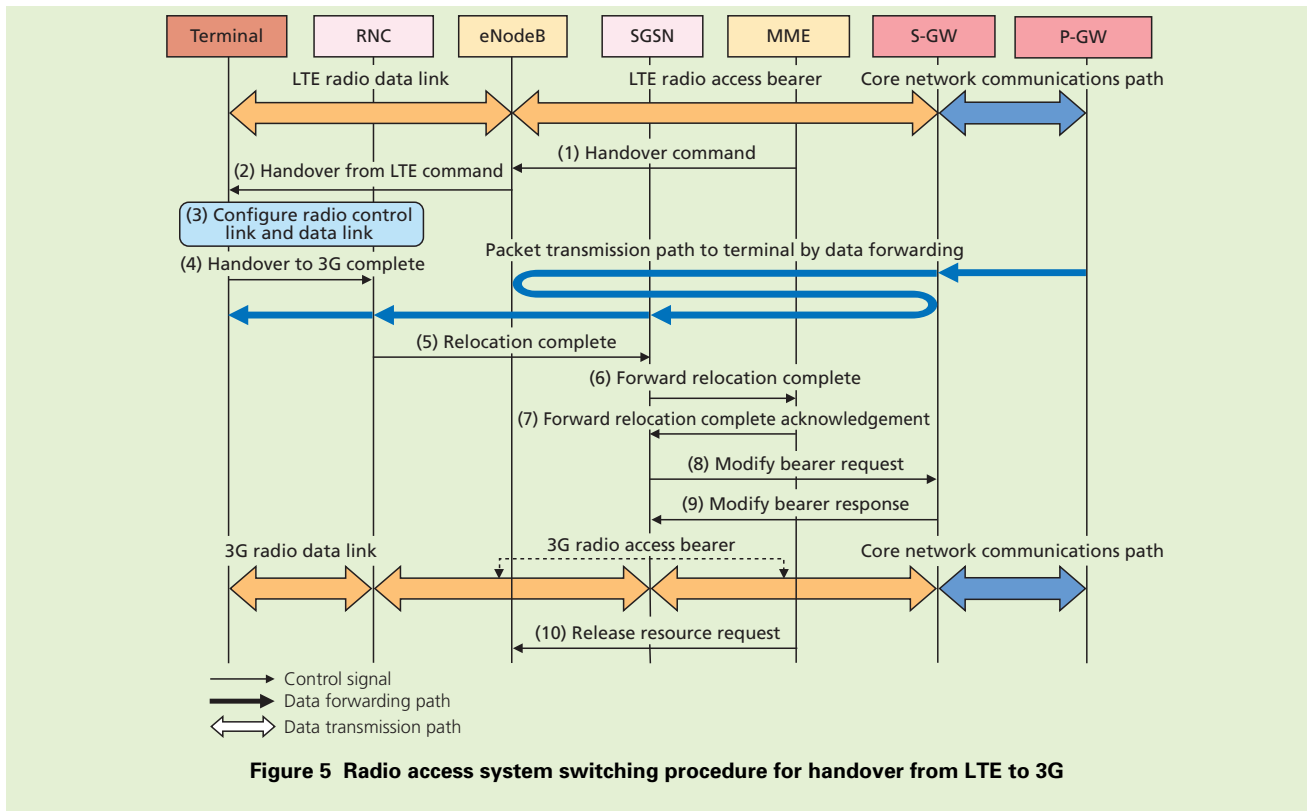

Figure 5 Radio access system switching procedure for handover from LTE to 3G

- Step (7):

The MME sends a forward relocation complete acknowledgement to the SGSN. A set period of time after receiving this signal, the SGSN releases the resources related to data forwarding.

- Step (8):

The SGSN sends a modify bearer request to the S-GW to change from the communications path before the handover, between the S-GW and eNodeB, to one between the S-GW and SGSN. This signal contains information elements required to configure the path from S-GW to SGSN, including those issued by the SGSN. When the

S-GW receives this signal, it configures a communications path from the S-GW to the SGSN. In this way, the communications path becomes: S-GW, SGSN, RNC, terminal; and data transmission to the target 3G radio access system begins.

Note that after this point, data forwarding is no longer needed, so the S-GW sends a packet to the eNodeB with an “End Marker” attached, and when the eNodeB receives this packet, it releases its resources related to data forwarding.

- Steps (9) to (10):

The S-GW sends a modify bearer response to the SGSN, indi-

cating that handover procedure has completed. The MME also releases eNodeB resources that are no longer needed.

Through this handover procedure, data is forwarded during the handover, the switch of radio access bearer is completed, and the communications path from the P-GW to the terminal is updated.

In the examples above, we described the handover procedure between 3GPP radio access systems in which the S-GW did not change, but handovers with S-GW relocation are also possible. In these cases, the P-GW provides the anchor function for path switching, as with

switches to non-3GPP access systems.

3.3 Functions Reducing Location Signaling for LTE/3G Handover

EPC can accommodate 3G as well as LTE radio access systems, and terminals can switch between radio systems according to signal conditions. Considering the scenario when LTE is first being introduced, the LTE radio area would be gradually developed, overlapping the 3G radio area, thus the LTE service areas could be limited. This could cause terminals near an LTE radio area edge to switch frequently between LTE and 3G radio access systems, even if they were not moving, and there is concern that this could result in effects such as an increase of network load due to terminal location registration and power consumption increases in terminals.

Thus, EPC provides an Idle-mode Signaling Reduction (ISR) function that makes it possible to omit the location registration when switching between LTE and 3G radio access systems as long as there is no location area change since a previous location registration over LTE or 3G. The ISR function can omit forwarding of the communications state when switching radio systems by preserving the same PDN connection state for the terminal, MME and SGSN (Connected PDNs, QoS conditions for the PDN connections, etc.).

With this function, when a terminal switches from 3G to LTE radio access systems while not communicating, for

example, if it has already registered its location when previously in the LTE area and there has been no change in the state of the PDN connection since it was in the LTE area, then no location registration is done.

Note that there is also a mechanism, called CS Fallback, that allows terminals initiating and receiving 3G circuit switching services while in an LTE area. With this function, existing 3G circuit switching services can be provided during the transition period to EPC. CS Fallback is achieved by making location registration for LTE and 3G circuit switching cooperative. Please see [8] for details.

3.4 Flexible Policy and Charging Management

With EPC, IP-based mobility management [9] is specialized as the communications path management function only, and policy and charging management, are provided by an independent management process called Policy and Charging Control (PCC)[10]. This allows it to implement a common architecture with other, non-3GPP AIPN such as the Next Generation Network (NGN)^{*13}. This PCC is able to manage policy and charging features, such as QoS management and packet filtering at gateways, flexibly according to the applications used by the user, such as IMS voice communication.

An overview of communications path management through IP-based

mobility management and policy and charging management through PCC is shown in **Figure 6**.

IP-based mobility management is implemented with a Local Mobility Anchor (LMA), which provides an anchor function for mobility management, and Mobility Access Gateways (MAG), which manage establishing and releasing communications paths between themselves and the LMA on behalf of the terminal. Please refer to [9] for details.

The PCC is composed of three logical entities: the PCRF, the Policy and Charging Enforcement Function (PCEF), and the Bearer Binding and Event Reporting Function (BBERF), as described below.

The PCRF determines the policy information (e.g.: priority and transmission permission rules in gateway) and charging information (e.g.: fees by packet volume) to be applied to each packet based on the user's contract and applications being used, as well as information regarding the packet being managed (e.g.: source/destination IP addresses, port numbers, etc.).

The PCEF enforces policy management and charging in IP-flow units according to the information received from the PCRF. The BBERF performs processing similar to the PCEF, but does not perform charging processing. The BBERF also performs any processing required to cooperate with access-system-specific QoS management (e.g.:

*13 NGN: A next generation communications network which provides the flexibility and economy of IP networks, while maintaining the reliability and stability of conventional telephone networks.

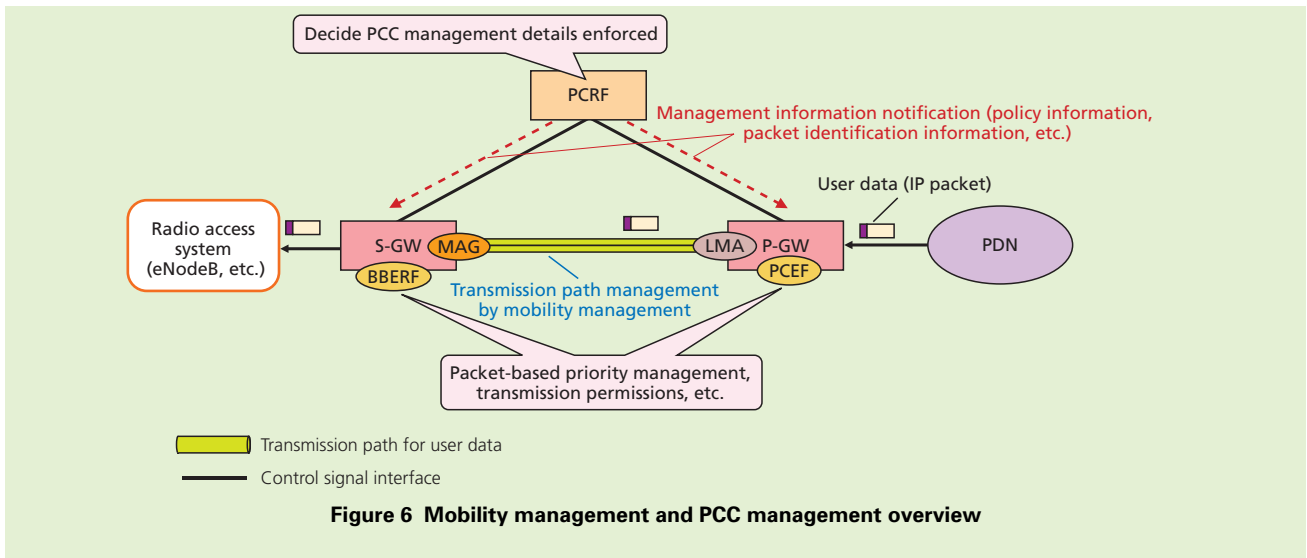

Figure 6 Mobility management and PCC management overview

specifying the LTE radio access bearer for transmitting a packet received from the P-GW to the eNodeB, etc.).

4. Conclusion

In this article we have described the architecture of EPC when accommodating LTE and 3G radio access systems, which was standardized in 3GPP Release 8 SAE, including functional characteristics and basic technologies used to implement them.

By having an always-on connection function when accommodating 3GPP radio access systems with EPC, communication processing time is reduced and high-speed handover with no packet loss during communication can be achieved. Also, LTE can be introduced smoothly through use of the ISR function. Policy and charging management can also be applied flexibly through the PCC mechanism.

Further development of EPC is con-

tinuing at the 3GPP with the Release 9 standardization. Completion of Release 9 is planned for December 2009, and is expected to add additional functions such as location information services on the LTE radio access system [11], to accommodate Home eNodeBs [12], and to provide priority management for IMS emergency calls [13].

REFERENCES

[1] T. Nakamura et. al: "Activity and Contributions for Completion of the 3GPP LTE/SAE Standard Specifications," NTT DOCOMO Technical Journal, Vol.11, No.2, pp.39-49, Sep. 2009.
 [2] 3GPP TS23.401 V8.6.0: "General Packet Radio Service (GPRS) enhancements for Evolved Universal Terrestrial Radio Access Network (E-UTRAN) access," Jun. 2009.
 [3] 3GPP TS23.402 V8.6.0: "Architecture enhancements for non-3GPP accesses," Jun. 2009.
 [4] 3GPP TR22.278 V8.8.0: "Service requirements for the Evolved Packet System (EPS)," Jun. 2009.
 [5] 3GPP TR22.258 V8.0.0: "Service Require-

ments for the All-IP Network (AIPN); Stage1," Mar. 2006.

[6] C.Sachno, et. al: "Standardization Trends at 3GPP for All-IP Networks," NTT DoCoMo Technical Journal, Vol.14, No.1, pp.85-91, Apr. 2006 (In Japanese).
 [7] 3GPP TS23.060 V8.5.1: "General Packet Radio Service (GPRS); Service description; Stage 2," Jun. 2009.
 [8] I.Tanaka et. al: "CS Fallback Function for Combined LTE and 3G Circuit Switched Services," NTT DOCOMO Technical Journal, Vol.11, No.3, pp.13-19, Dec. 2009.
 [9] J.Laganier et. al: "Mobility Management for All-IP Core Network," NTT DOCOMO Technical Journal, Vol.11, No.3, pp.34-39, Dec. 2009.
 [10] 3GPP TS 23.203 V8.6.0: "Policy and charging control architecture," Jun. 2009.
 [11] 3GPP TS 23.271 V9.0.0: "Functional stage 2 description of Location Services (LCS)," Jun. 2009.
 [12] 3GPP TR 23.830 V0.5.0: "Architecture aspects of Home NodeB/Home eNodeB," Jun. 2009.
 [13] 3GPP TS 23.167 V9.1.0: "IP Multimedia Subsystem (IMS) Emergency Sessions," Jun. 2009.